

Adjustment

! Some listed items are offered separately.

Patent Pending

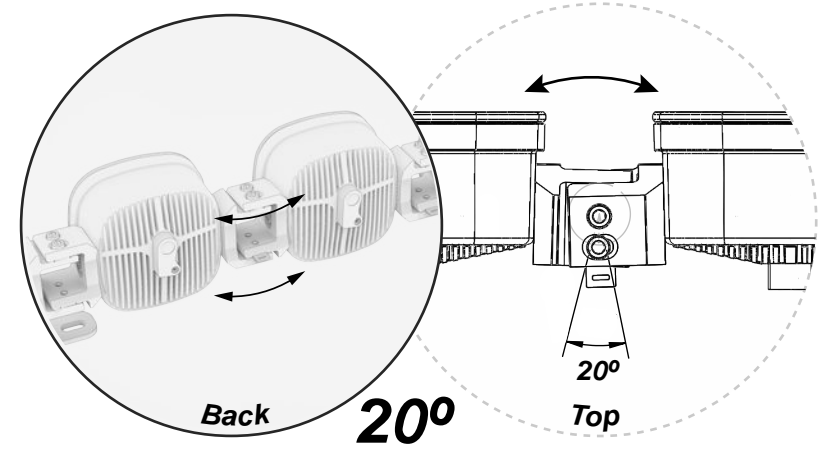

Out of the Box

Perform the following on a flat table after receiving! - Do this before mounting.

Figure 1

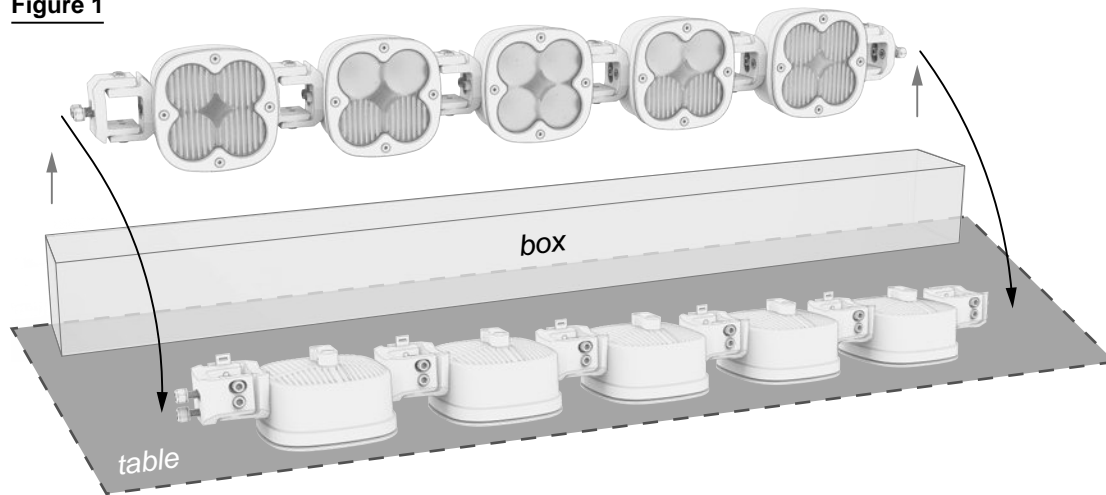
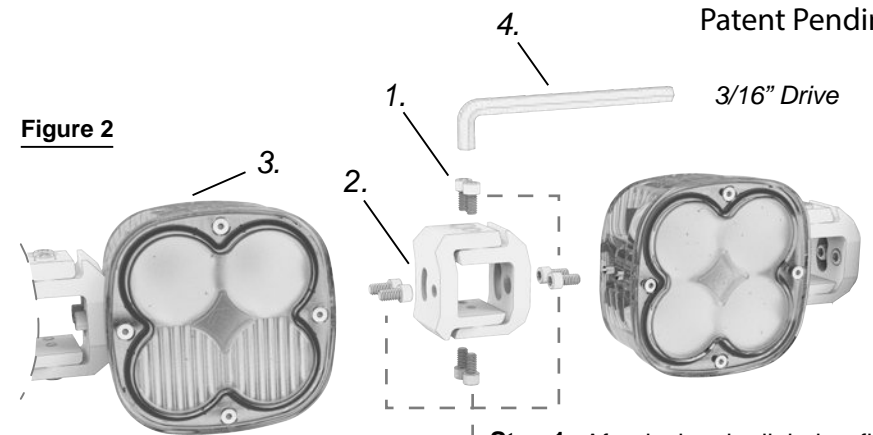

Figure 2



Step 1. After laying the light bar flat on a table, start from one side and adjust one axis at a time by loosening the indicated 1/4"-20 screws¹ on each link² to allow each light pod³ to rest flat on the table. A 3/16" Allen Wrench⁴ is included.

Step 2. With each light pod flat against the table, tighten all the 1/4"-20 screws

Assembling Pre-Load Mechanism

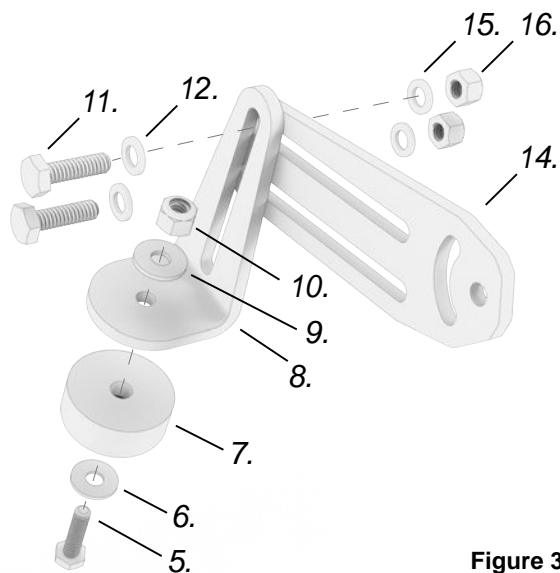

Figure 3

Step 3. Required for (6-8) Lights

Using a 7/16" socket and wrench, assemble items (5 - 10). Refer to Figure 4 and Figure 6 (on next page) for the location and orientation of the Pre-Load Base¹⁴ and Extension⁸.

- 5. 1/4"-20 x 1.00" Hex Head Bolt
- 6. 1/4" Oversized Washer
- 7. Rubber Bump Stop
- 8. Pre-Load Base Extension
- 9. 1/4" Oversized Washer
- 10. 1/4" Nylock Nut

Step 4. Then, assemble items (11 - 16) in the order shown in Figure 3.

- 11. 1/4"-20 x 7/8" Head Head Bolt
- 12. 1/4" Washer
- 14. Pre-Load Base
- 16. 1/4" Nylock Nut

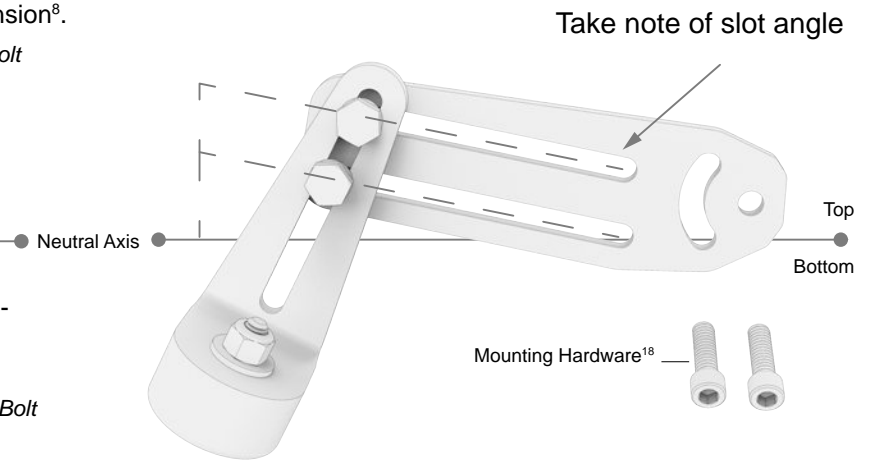

Figure 4

Attaching Pre-Load Mechanism

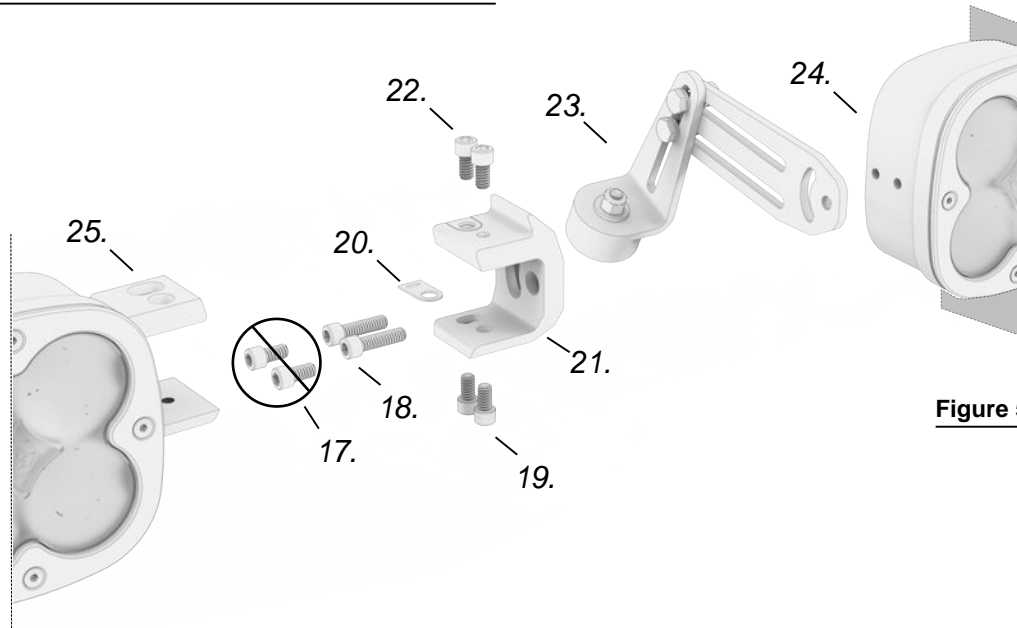

Figure 5

Step 5. Refer to Figure 6 in order to locate which Socket Head Cap Screws^(19, 22) to unscrew.

For the number of lights the XL Linkable has, locate that diagram in Figure 6. Unscrew the top and bottom Socket Head Cap Screws to the right of the Pre-Load Mechanism that secure the XL Links together. Separate as shown in Figure 5.

(17, 19, 22.) 1/4"-20 x 7/16 Socket Head Cap Screw

Step 6. Replace the 1/4"-20 x 7/16" Cap Screw¹⁷ with the included 1/4"-20 x 7/8" Cap Screw¹⁸. Assemble items (18-25) in the order shown in Figure 5.

17. 1/4"-20 x 7/16 Socket Head Cap Screw

18. 1/4"-20 x 7/8" Socket Head Cap Screw

20. Zip Tie Tab (on harness)

(21, 25.) Link

23. Pre-Load Mechanism

24. XL Housing

Positioning Pre-Load Mechanism

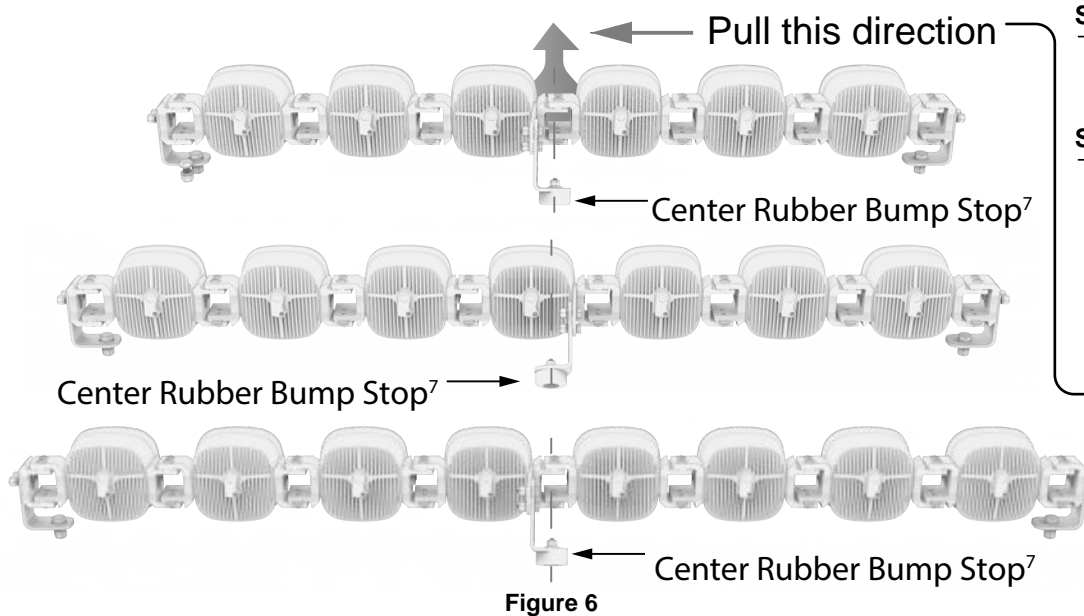

Figure 6

Step 7. Check to make sure the Rubber Bump Stop⁷ is centered on the XL Linkable as shown in Figure 6.

Step 8. **The Pre-Load Mechanism is required for 6+ lights.** To reduce vibration and increase stiffness of the XL Linkable, add pre-load.

Make sure all Socket Head Cap Screws are tight. Using a 7/16" ratchet and wrench, loosen the 1/4"-20 x 7/8" Hardware¹¹ a quarter turn such that it can pivot.

Pull the XL Linkable away from the vehicle (indicated by shaded arrow in Figure 6), and then tighten the Hardware¹¹ with the Rubber Bump Stop⁷ firmly resting on the included 3M[®] Clear Bra²⁶, perpendicular (Figure 7), on a sturdy surface.

Figure 7

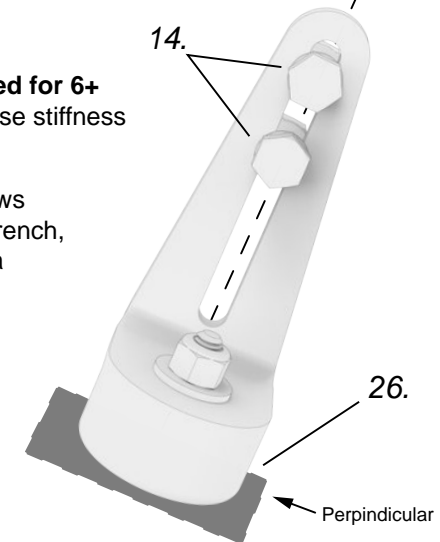

Liability Disclaimer

The XL Linkable has been designed and tested around Baja Designs' vehicle specific mounting solutions, and under responsible driving conditions. Baja Designs releases liability on damage that can occur by using a third-party mounting solution. Baja Designs is not liable under any circumstance for damages or bodily harm due to irresponsible driving, improper application/mounting, and/or negligence of recommended maintenance.

- It is advised that installation be performed by a Baja Designs Authorized Dealer.
- Installation is recommended to be performed by at least two individuals in a safe work environment.
- The recommended number and location(s) of the Baja Designs Pre-Load Mechanism(s) must be installed for a specific vehicle.

 Please Shred Responsibly 

How to Mount

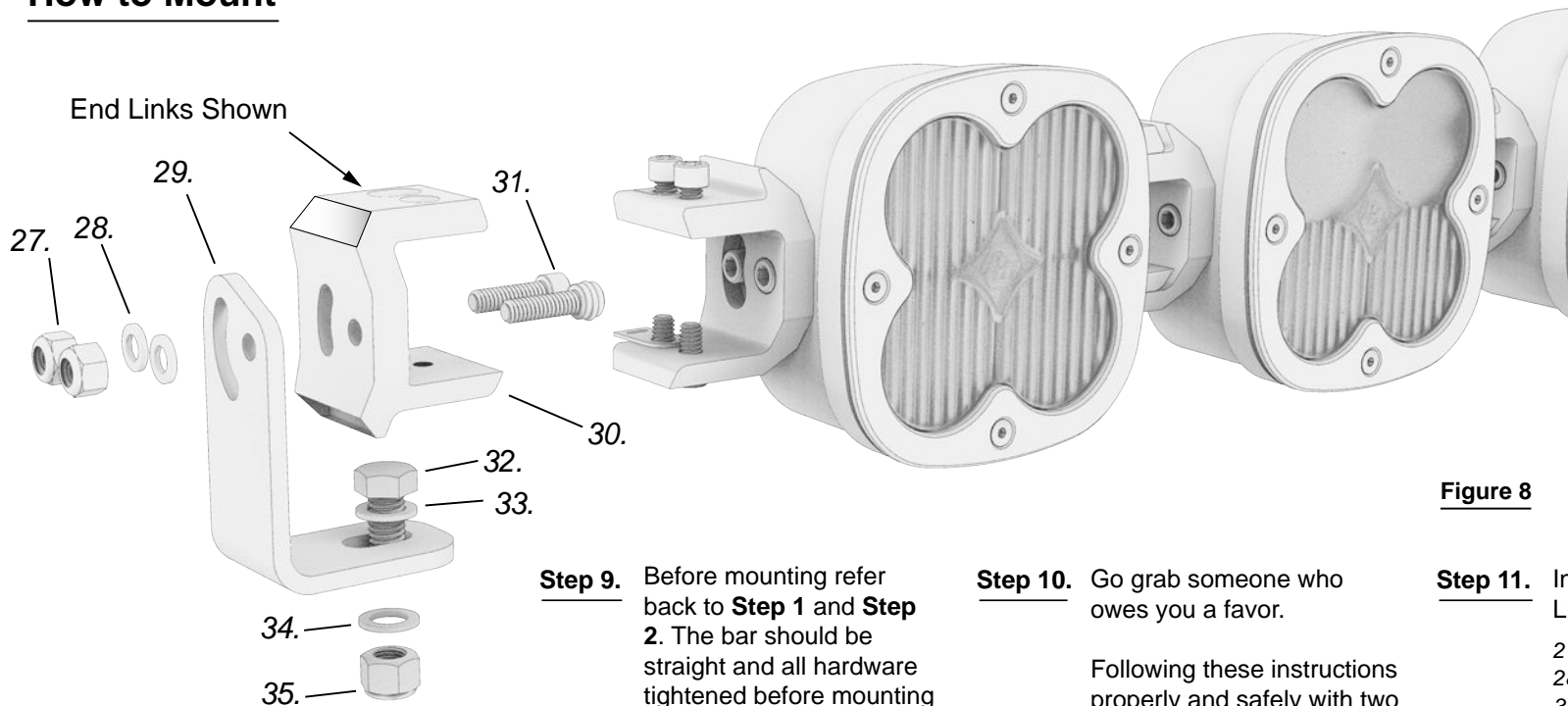

Step 12. Using the included hardware in the XL Linkable Universal Bracket Kit (available separately), orient the Hardware^(32, 33, 34, 35) as shown in Figure 8.

Tighten the 3/8" hardware with a 9/16" ratchet and wrench.

Adjust the pitch of the entire XL Linkable and tighten in place.

32. 3/8" x 7/8" Hex Head Bolt
33, 34.) 3/8" Washer
35. 3/8" Nylock Nut

Figure 8

Step 9. Before mounting refer back to **Step 1** and **Step 2**. The bar should be straight and all hardware tightened before mounting the XL Linkable to any brackets.

Confirm that the Pre-Load Mechanism²³ is installed properly. Refer to **Step 3** through **Step 8**.

Step 10. Go grab someone who owes you a favor.

Following these instructions properly and safely with two people will make for a properly aimed and adjusted light that you can shred 'dem trails and dunes with.

Step 11. Included in the parts bag for the XL Linkable are four of each:

27. 1/4" Nylock Nut
28. 1/4" Washer
31. 1/4"-20 x 7/8" Socket Head Cap Screw

Without removing any Hardware, secure the bracket (XL Universal Bracket²⁹ shown) using the two 1/4"-20 x 7/8" Socket Head Cap Screws³¹ and 1/4" Nylock Nuts³⁰ on each side in orientation shown in Figure 8.

Figure 9

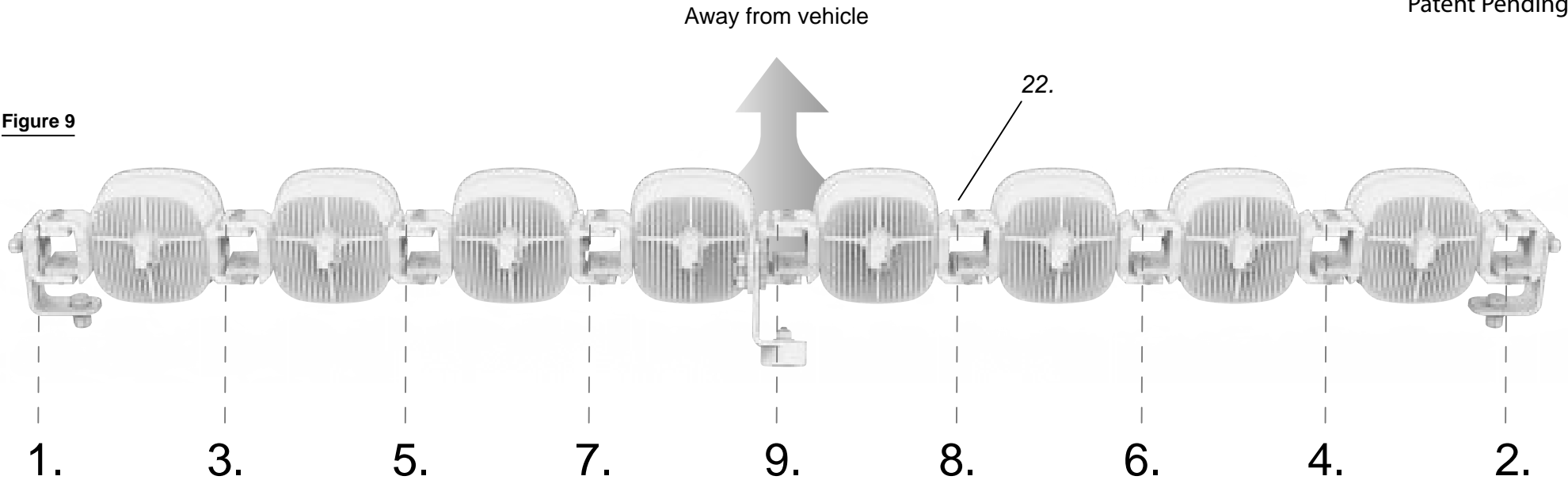

How to Arc

Step 13. Start at the set of links indicated by the **number 1** in the diagram above. Barely loosen BUT DO NOT REMOVE the **top and bottom** 1/4"-20 x 7/16" Socket Head Cap Screws²² using the included 3/16" Allen Wrench⁴ or a Hex Bit.

Transition to the opposite side. In this case, loosen the top and bottom hardware at the set of links indicated by the **number 2**.

Loosen in pairs (i.e. 1&2, 3&4), and pull the XL Linkable away from the vehicle as shown in Figure 9 after loosening each pair of links until the desired arc and light spread are achieved.

Step 14. Tighten, in pairs and in the reverse order as done previously, making sure that each pair of links is tight before moving onto the next pair of links. Pull the XL Linkable away from the vehicle with steady force while tightening the Hardware²².

How to Pitch

Step 15. Removing XL Links are not necessary to adjust the pitch.

To individually pitch individual or sets of XL's, use the included 3/16" Drive Allen Wrench⁴ to loosen the four outmost 1/4"-20 Socket Head Cap Screws³⁶ securing the XL Link³⁷ to the XL Light³⁸.

This will allow you pitch entire sections of the XL Linkable.

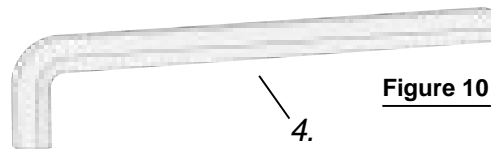

Figure 10

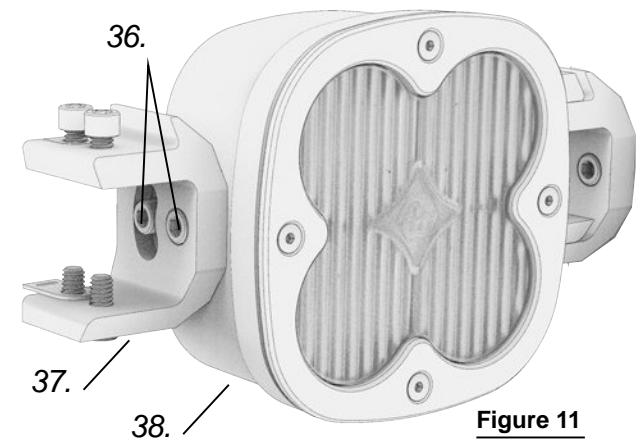
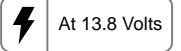





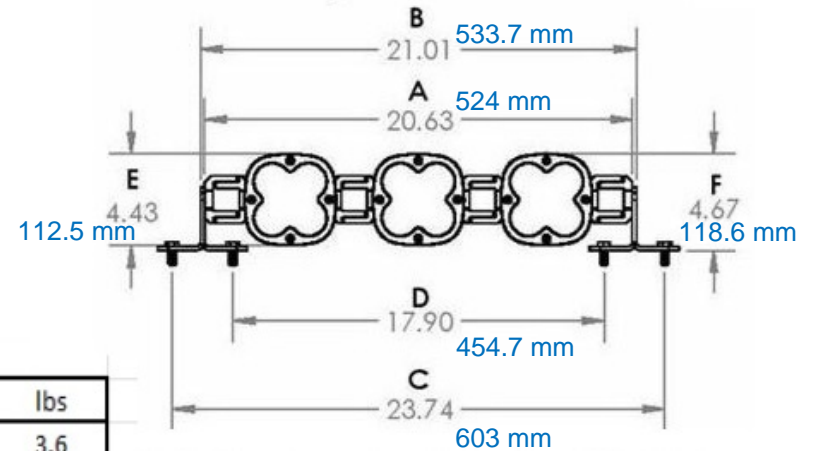
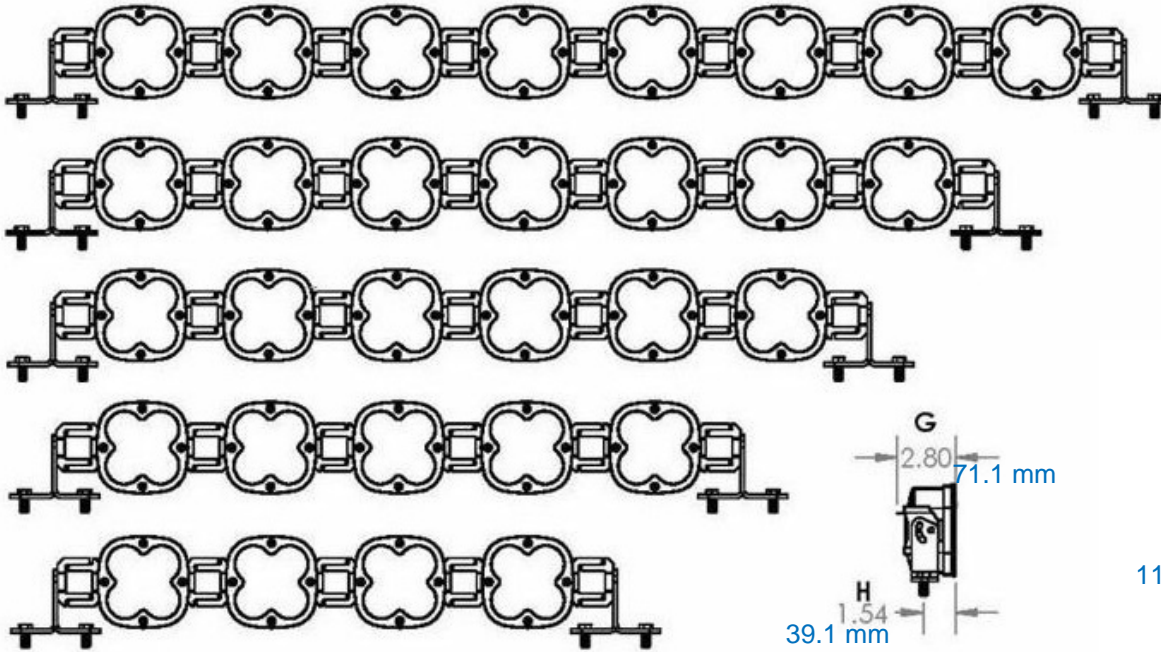
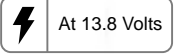

Figure 11

General Dimensions



Lights	Lens Patterns	(Straight - Arced)	Power
3	 D.C. SPOT D.C.	(20.77 - 20.82") 527.6 to 528 mm	78W
4	 D.C. SPOT SPOT D.C.	(26.94 - 26.99") 584.3 to 685.5 mm	104W
5	 W.C. D.C. SPOT D.C. W.C.	(33.14 - 33.16") 841.8 to 842.3 mm	130W
6	 W.C. D.C. SPOT SPOT D.C. W.C.	(39.31 - 39.32") 998.5 to 998.7 mm	156W
7	 W.C. D.C. SPOT SPOT SPOT D.C. W.C.	(45.49 - 45.47") 1155.4 to 1154.9 mm	182W
8	 W.C. D.C. SPOT SPOT SPOT SPOT D.C. W.C.	(51.67 - 51.20") 1312.4 to 1300.5 mm	208W



Note: Each mounting bolt is in a slotted hole. Dimension D and C represent the center of the slot in the mounting brackets. The slot allows for 0.1875" of adjustment each direction from center. Also, Six lights and above will use a support bracket that will add 0.188" to A, B, C, and D dimensions.

Imperial	A	B	C	D	E	F	G	H	lbs
3 Lights	20.63	20.01	23.74	17.90	4.43	4.67	2.80	1.54	3.6
4 Lights	26.81	27.19	29.92	24.08	4.43	4.67	2.80	1.54	5.0
5 Lights	32.99	33.37	36.09	30.25	4.43	4.67	2.80	1.54	6.4
6 Lights	39.16	39.55	42.27	36.43	4.43	4.67	2.80	1.54	7.7
7 Lights	45.34	45.73	48.44	42.61	4.43	4.67	2.80	1.54	9.5
8 Lights	51.52	61.91	54.62	48.79	4.43	4.67	2.80	1.54	10.9

Metric	A	B	C	D	E	F	G	H	kg
3 Lights	524.00	508.25	603.00	454.66	112.52	118.62	71.12	39.12	1.6
4 Lights	680.97	690.50	759.97	611.63	112.52	118.62	71.12	39.12	2.3
5 Lights	837.95	847.60	916.69	768.35	112.52	118.62	71.12	39.12	2.9
6 Lights	994.66	1004.44	1073.66	925.32	112.52	118.62	71.12	39.12	3.5
7 Lights	1151.64	1161.54	1230.38	1082.29	112.52	118.62	71.12	39.12	4.3
8 Lights	1308.61	1572.51	1387.22	1239.27	112.52	118.62	71.12	39.12	4.9

PATENT PENDING



Performace Overview Diagrams

Straight Versus Arced

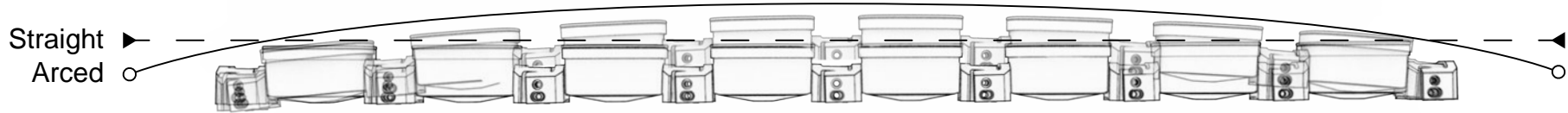

Optical Heat Map 8 Lights

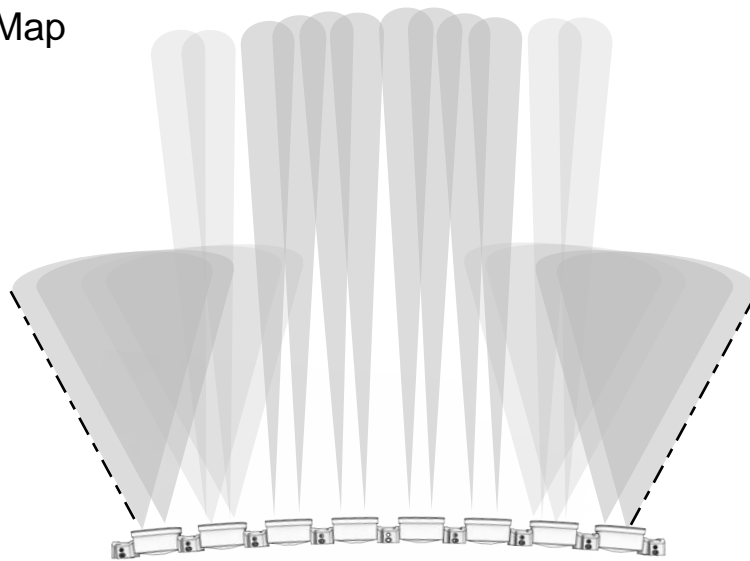

Straight
44° Spread

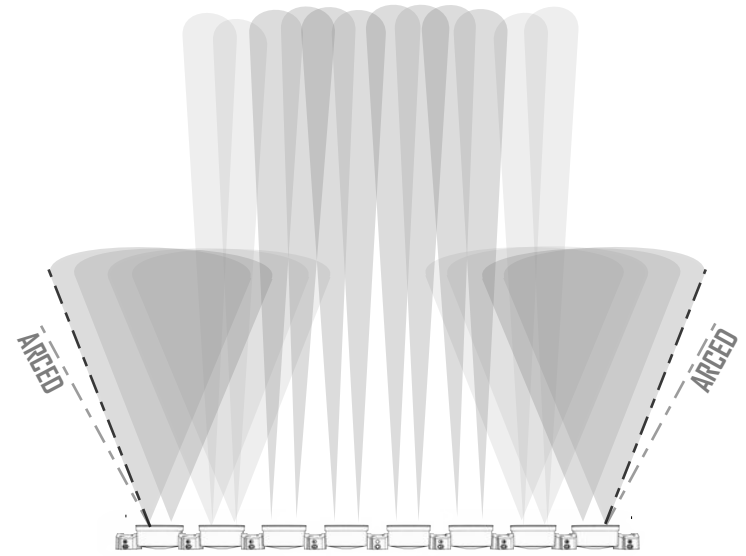

Arced
64° Spread



bajadesigns®

THE SCIENTISTS OF LIGHTING

185 Bosstick Boulevard
Aan Marcos, CA 92069

Phone: 760-560-2252 info@bajadesigns.com
Fax: 760-560-0363 www.bajadesigns.com

LIMITED LIFETIME WARRANTY

Baja Designs proudly offers a LIFETIME WARRANTY against manufacturer's defect on all of the products that we manufacture.

These are comprehensive warranties; other than the exclusions below - you're covered. If your LED or HID bulb burns out, you're covered. Additionally, cutting off our connector or changing your lenses does not automatically void your warranty.

Exclusions:

Installation errors, abuse, misuse or crash damage. You must be the original owner of the product and can supply proof of purchase.

Baja Designs manufactures its own products as well as resells products manufactured by others. Baja Designs makes no express or implied warranties on products not manufactured by Baja Designs including without limitation any warranties or merchantability and fitness for a particular purpose. We will however, pass on all warranties made by the manufacturer, who has sole responsibility for performing such warranties.

Baja Designs will pay the freight if your product is less than 90 days old, otherwise defective products must be returned to Baja Designs, Inc., freight prepaid. At our option, we will repair or replace items in question and return them at no charge. If the identical product is no longer available, we will replace with a similar product of equal value. Baja Designs Inc. will not be responsible for any indirect or consequential damages in connection with defective merchandise.

Items purchased through a Baja Designs authorized dealer must be returned through the dealer. Only available on LED auxiliary lights and product must be in sellable condition at MSRP. Product that has been damaged in any way after the original purchase date will be excluded from this guarantee

Indemnification:

Buyer hereby acknowledges off-roading, racing and driving at night are dangerous activities and that the products and/or supplies purchased from Baja Designs are used in an inherently dangerous activity that may endanger life and limb; and in no event shall the seller, or seller's heirs and assigns, be held liable for consequential damages, nor shall seller's liability on any claim for damages arising out of or connected with the sale, delivery, or use of purchased products and/or supplies exceed the purchase price of the products and/or supplies.