

LP9 PRO



 STOTTS



Description:

A design that was inspired by Baja Designs' legendary 8" La Paz HID; The LP9 features modern styling and performance, with some of the most advanced LED technologies available today.

The LP9 utilizes 9 forward projecting LEDs to produce 11,025 Lumens at 105 watts, and 6 LEDs for Integrated Peripheral Technology (IPT) which produce 1,140 lumens at 10.5 watts per side. The IPT provides an incredible 200° spread of usable light.

The housing was designed to provide exceptional heat dispersion by using Direct Ducted Cooling, which allows air to travel from the front of the housing to the rear. With a day-time running light, low, and high power mode, the LP9 will fulfill all your lighting needs.

Available in a standard model that is perfect for a wide range of off-road use, as well as a Racer Edition configuration that is designed for the demands of high speed driving. The Racer Edition has similar power draw, but produces a much tighter pattern, providing higher visibility at greater distances. Both models feature uService technology, which allows customers to change the lens pattern and color depending on driving conditions, or simply when they want to refresh the lens.

Specifications:

Forward Projecting Lumens: 11,025 Utilizing 9 LEDs

Forward Projecting Wattage/Amps: 105W / 7.6A

IPT Lumens: 2,280 Utilizing 6 LEDs

IPT Wattage/Amps: 21W / 1.52A

Dimensions: 8" Diameter/ 3.25" Depth

Weight: 6.5lbs

LED Life Expectancy: 49,930 Hours

Front Lens: Hardcoated Polycarbonate

Housing: Hard Anodized Machined Aluminum

Bezel: Billet Machined Aluminum

Hardware & Bracket Material: Stainless Steel

Exceeds MIL-STD810G (Mil-Spec Testing)

Built-In Overvoltage Protection

IP69K (Waterproof up to 9ft & Pressure Washable)

IK10 Compliant (Mechanical Impact Testing)

Baja Designs Features:

- **Satisfaction Guaranteed** - 30 Day Money Back Guarantee
- **Limited Lifetime Warranty** - Complete Purchase Protection
- **uService®** - Replaceable Lenses And Optics
- **ClearView®** - All The Light, Right Where You Need It
- **MoistureBlock™** - Waterproof, Rain Proof, Submersible
- **CopperDrive®** - Only LED Driven At 100%
- **5000K Daylight** - Less Driver Fatigue, Natural Color

www.baja.net.au

12/5/23

PO Box 3315 Thornton NSW 2322. Unit 1, 13 Elwell Close (Cnr Bowden Way), Beresfield NSW 2322. Tel 02 4966 8020

Email sales@stottind.com.au

Web www.stottind.com.au

ABN 70 114 974 784

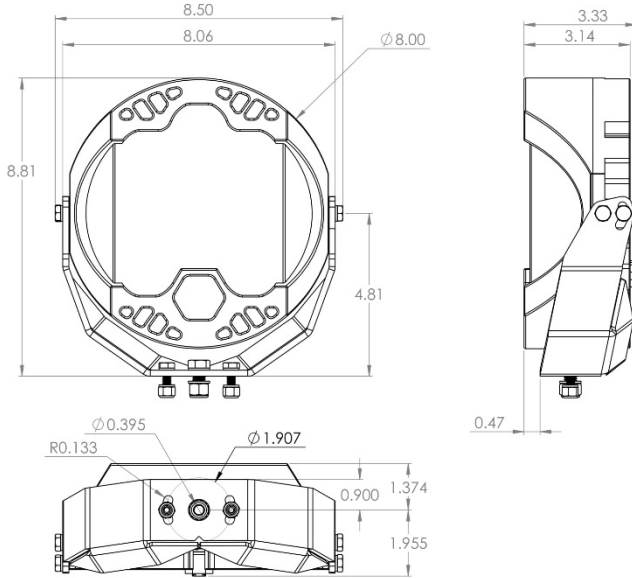

Part Number	Description	Size	Lumens	Amps/Watts
32-0001	LP9 Pro, LED, Spot	8" Diameter/ 3.25" Depth	Forward Projecting Lumens: 11,025 Utilizing 9 LEDs IPT Lumens: 2,280 Utilizing 6 LEDs	Forward Projecting Wattage/Amps: 105W / 7.6A IPT Wattage/Amps: 21W / 1.52A
32-0003	LP9 Pro, LED, Driving/Combo	8" Diameter/ 3.25" Depth	Forward Projecting Lumens: 11,025 Utilizing 9 LEDs IPT Lumens: 2,280 Utilizing 6 LEDs	Forward Projecting Wattage/Amps: 105W / 7.6A IPT Wattage/Amps: 21W / 1.52A
32-0011	LP9 Pro, LED, Spot, Amber	8" Diameter/ 3.25" Depth	Forward Projecting Lumens: 11,025 Utilizing 9 LEDs IPT Lumens: 2,280 Utilizing 6 LEDs	Forward Projecting Wattage/Amps: 105W / 7.6A IPT Wattage/Amps: 21W / 1.52A
32-0013	LP9 Pro, LED, Driving/Combo, Amber	8" Diameter/ 3.25" Depth	Forward Projecting Lumens: 11,025 Utilizing 9 LEDs IPT Lumens: 2,280 Utilizing 6 LEDs	Forward Projecting Wattage/Amps: 105W / 7.6A IPT Wattage/Amps: 21W / 1.52A

LIMITED LIFETIME WARRANTY

www.baja.net.au

Baja Designs proudly offers a LIFETIME WARRANTY against manufacturer's defect on all of the products that we manufacture. These are comprehensive warranties; other than the exclusions below - you're covered. If your LED or HID bulb burns out, you're covered. Additionally, cutting off our connector or changing your lenses does not automatically void your warranty.



Exclusions:

Installation errors, abuse, misuse or crash damage. You must be the original owner of the product and can supply proof of purchase.

Baja Designs manufactures its own products as well as resells products manufactured by others. Baja Designs makes no express or implied warranties on products not manufactured by Baja Designs including without limitation any warranties or merchantability and fitness for a particular purpose. We will however, pass on all warranties made by the manufacturer, who has sole responsibility for performing such warranties.

Baja Designs will pay the freight if your product is less than 90 days old, otherwise defective products must be returned to Baja Designs, Inc., freight prepaid. At our option, we will repair or replace items in question and return them at no charge. If the identical product is no longer available we will replace with a similar product of equal value. Baja Designs Inc. will not be responsible for any indirect or consequential damages in connection with defective merchandise.

Items purchased through a Baja Designs authorized dealer must be returned through the dealer. Only available on LED auxiliary lights and product must be in sellable condition at MSRP. Product that has been damaged in any way after the original purchase date will be excluded from this guarantee

Indemnification:

Buyer hereby acknowledges off-roading, racing and driving at night are dangerous activities and that the products and/or supplies purchased from Baja Designs are used in an inherently dangerous activity that may endanger life and limb; and in no event shall the seller, or seller's heirs and assigns, be held liable for consequential damages, nor shall seller's liability on any claim for damages arising out of or connected with the sale, delivery, or use of purchased products and/or supplies exceed the purchase price of the products and/or supplies.

LP9 Mounting Instructions



www.baja.net.au



- 1) Begin by removing the light and bracket from the box and orientate them as shown in the picture above.
- 2) Locate the 1/4"-20 and 3/8" hardware in the provided hardware pack, and place center 3/8" bolt and two 1/4"-20 bolts and associated washers through the bottom of the bracket. Use provided washers and nuts below the mounting surface tighten down after alignment.
- 3) Mount the bracket to the light using the remaining 1/4"-20 hardware (4 bolts and 4 washers).

Lens Swap Instructions (uService):

- When installing a different lens simply remove the 6 allen head bolts using a 4mm allen wrench on the back of the of the light.
- Carefully remove the front bezel and lens.
- Make sure that the o-ring is properly fitted in o-ring groove in the housing when installing the new lens and bezel. The o-ring is not directional but its shape was designed to match the groove in the housing.
- Reinstalling the bezel will give you a brand-new lens and pattern, depending on your preference.
- The bezel should be torqued to 7 ft./lb. in a "criss-cross" pattern.

1. LP9 Wiring Instructions LP9 Sport Wiring Instructions

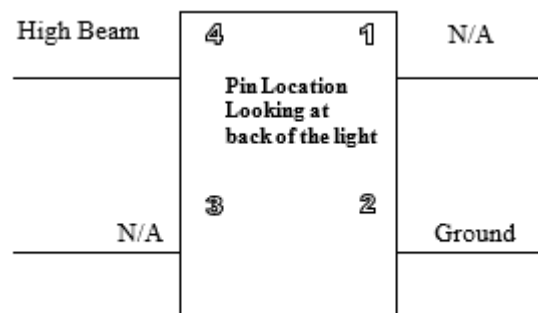
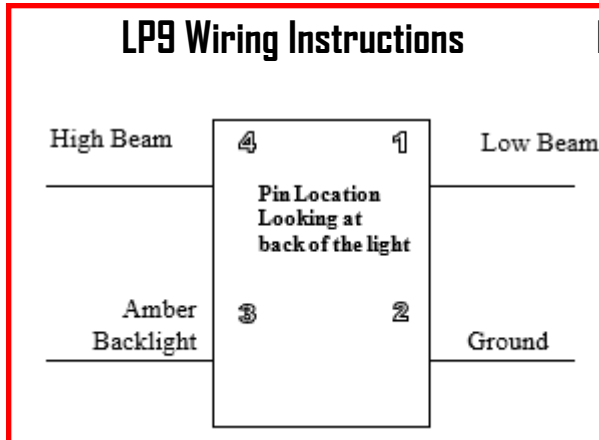

- The LP9 is able to run at 12-36 Volts.
- Low beam, high beam and Amber Back light function off positive current.
- **Do NOT power pins 1 and 4 at the same time.** This may cause damage to the circuit board!
- If you are creating your own wiring harness the mating connector for the back of the light is a Deutsch Connector with part number DT06-4S. When you wire the light, you cannot supply power to the low beam (pin 1) & the high beam (pin 4) at the same time. **Use a three position toggle switch (on/off/on) that is single pole, double**



throw. In one of the on position's it will supply power to the low beam. In the opposite on position it will supply power to the high beam. Custom wire harnesses must be made with 12 gauge wire for pins 1, 2, & 4. Pin three must use a minimum of 16 gauge wire. If The minimum size wire is not used, fire of damage to the light may occur.

We highly recommend use of our 64-0172, LP9 Pro Wire Harness to safely power up to two lights at a time. The 64-0172 includes switch, relay, connectors and ample lengths of wire for a full size truck.

LP9 Wire Harness Schematic

Hella Relay
PN: 4RD 933 332-18

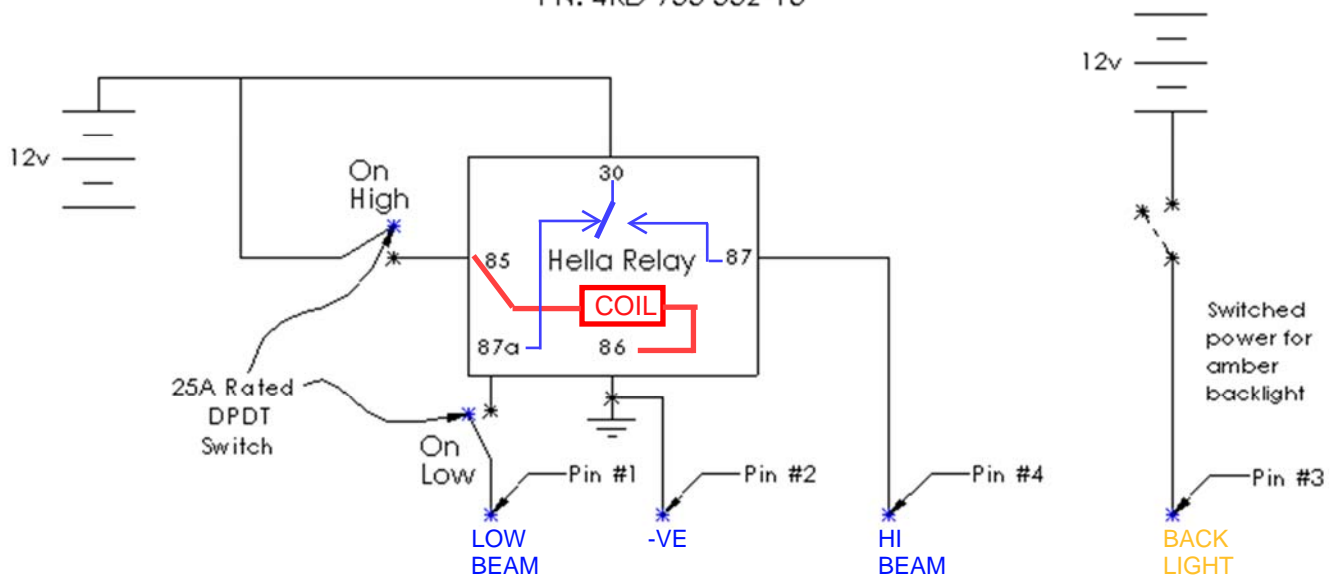

4 Pin Connector

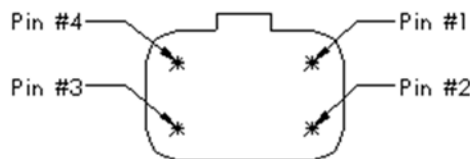

www.baja.net.au

Disclaimer: We take all efforts to ensure that this information is correct, however sometimes, errors do appear, and we value your support if you notice any. However the information is subject to review without notice.

GENERAL COMMENT PAGE

SPOT DESIGN SHOWN

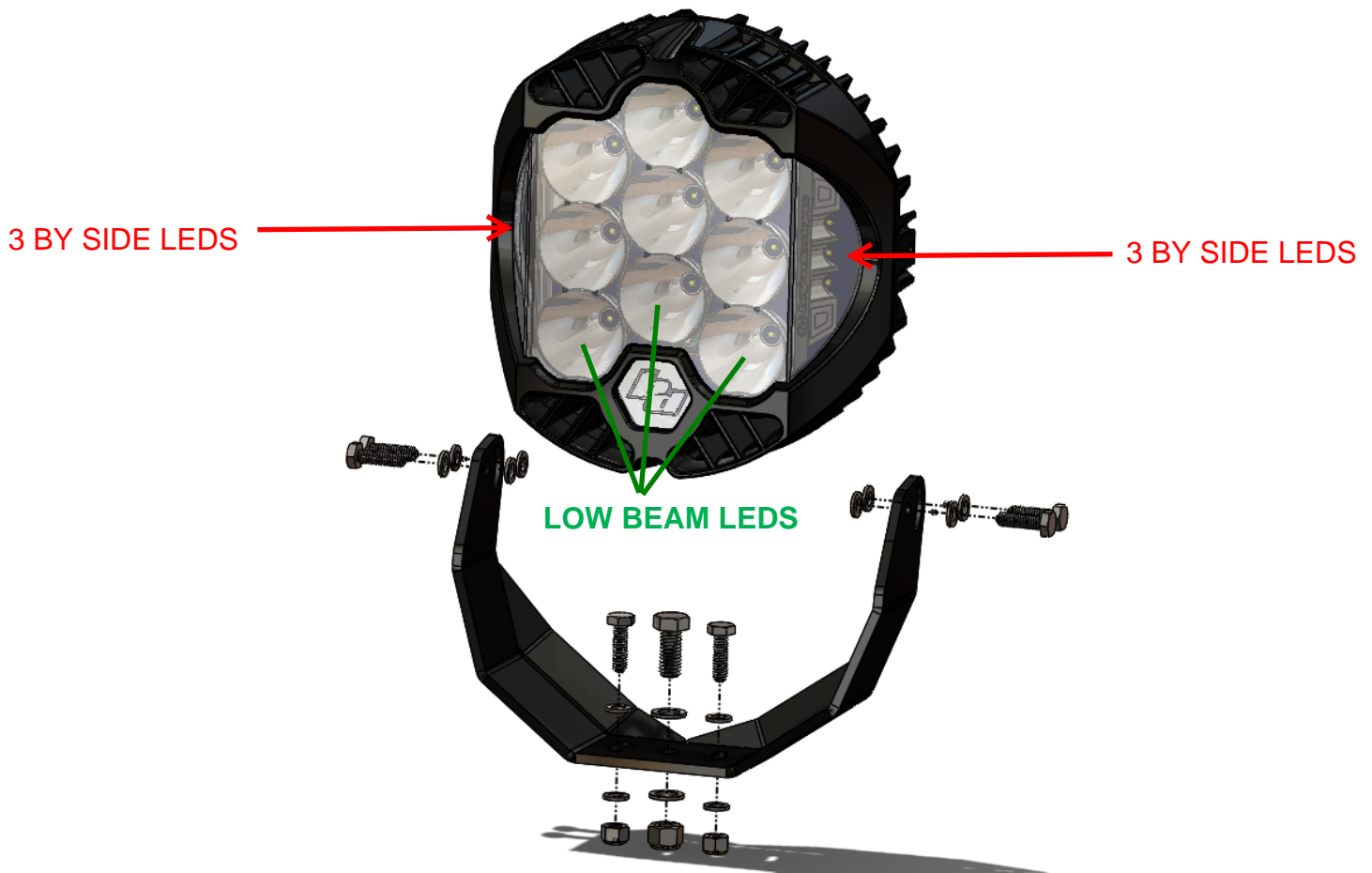

OPERATION IN SIMPLE TERMS

PIN 1 - LOW BEAM HAS POWER APPLIED
ALL 6 SIDE LEDS ILLUMINATE
THE 3 LOW BEAM LEADS (SHOWN WITH GREEN ILLIMINATE).

PIN 4 - HIGH BEAM POWER APPLIED
ALL 6 SIDE LEDS ILLUMINATE
THE 3 LOW BEAM LEADS (SHOWN WITH GREEN ILLIMINATE).
THE TOP 6 FRONT LEDS ILLUMINATE
THAT IS ALL LEDS ARE ON

WHEN PIN 4 IS POWERED DO NOT POWER PIN 1
THIS MAY DAMAGE THE PRINTED CIRCUIT BOARD, AND IS NOT A WARRANTY CLAIM.

185 BOSSTICK BOULEVARD
 SAN MARCOS, CA 92069

PHONE 760-560-2252
 FAX 760-560-0383

INFO@BAJADESIGNS.COM
 WWW.BAJADESIGNS.COM

CONNECTOR WIRING INSTRUCTIONS

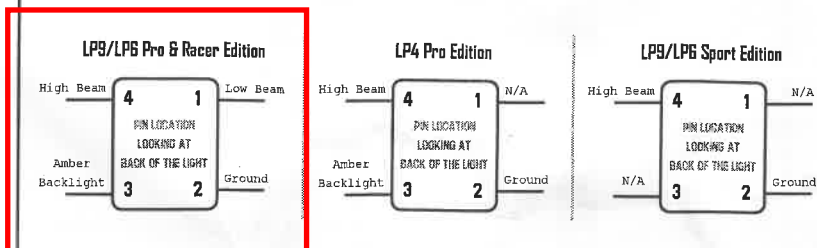

- LP9, LP6, and LP4 Operating Voltage: 12-36 Volts.
- Low Beam, High Beam, and Amber Backlight function off positive current.
- DO NOT Power Pins 1 and 4 at the same time.** This may cause damage to the circuit board - not covered under warranty.
- If you are creating your own wiring harness, the mating connector for the back of the light is a Deutsch Connector (DT06-4S). When wiring the light, you cannot supply power to the low beam (Pin 1) & the High Beam (Pin 4) at the same time.

Wiring a single light from power source = 14 ga wire.

Wiring two light = 12 ga from power source, 14 ga from split junction.

Use a three position toggle switch (on/off/on) that is Double Pole, Double Throw (DPDT). In one of the On positions, it will supply power to the low beam. In the opposite On position, it will supply power to the high beam. Custom wire harnesses must be made with 12 gauge wire for Pins 1, 2, and 4. Pin 3 must use a minimum of 16 gauge wire. If the minimum size wire is not used, fire, or damage to the light may occur.

We highly recommend the use of our 64-0172, LP9 Pro Wire Harness to safely power up to two lights at a time. The 64-0172 includes a switch, relay, connectors, and ample lengths of wire for a full size vehicle.

LP9 LP6 LP4

MOUNTING INSTRUCTIONS (LP9 uses washers on the inside, LP6 & LP4 do not!)

- Begin by removing the light and bracket from the box and orient them as shown in the picture.
- Locate the 1/4"-20 and 3/8" hardware in the provided hardware pack, placing the center 3/8" bolt, two longer 1/4"-20 bolts, and associated washers through the bottom of the bracket as shown in the picture. Do not fully tighten the lower mounting bracket hardware until the light has been aligned.
- Mount the bracket to the light using the remaining 1/4"-20 hardware as shown in the picture.

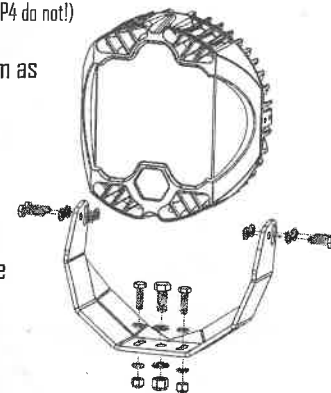

LENS SWAP INSTRUCTIONS



- When installing a different lens, simply remove the 6 (LP9) or 4 (LP6 & LP4) bolts using a 4mm allen wrench on the back of the light.
- Carefully remove the front bezel and lens.
- Make sure the o-ring is properly fitted in the o-ring groove of the housing when installing the new lens. The o-ring is not directional, although the shape has been designed to match the housing profile groove.
- Once you have ensured the o-ring, lens, and bezel has been properly seated, begin tightening the 6 (LP9) or 4 (LP6 & LP4) bolts. The bezel hardware should be torqued to 25 lbf-in in a "criss-cross" pattern.

LP SERIES WIRING HARNESS SCHEMATIC (Relay PN: 4RD 933 332-18)

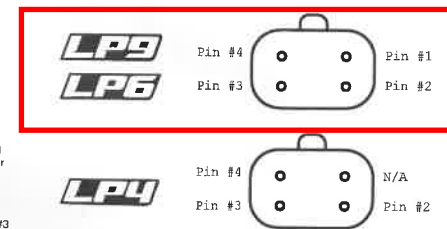
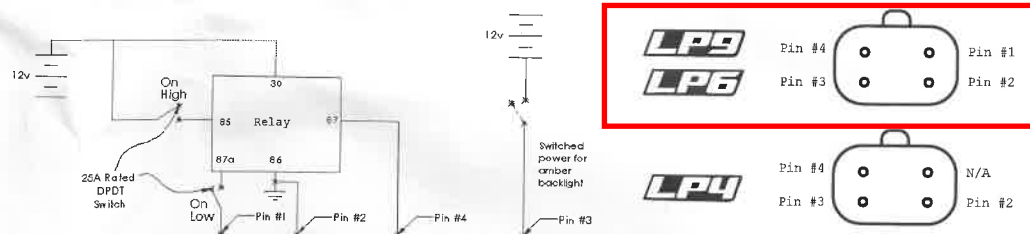

Looking at back of light



Have a look on YOUTUBE
Repco Reliability Retrial - Car #127 with Baja Lights
<https://youtu.be/clgliXTv52Y>